

NK PIR832

Installation instructions

Curtain style PIR detector with direction recognition

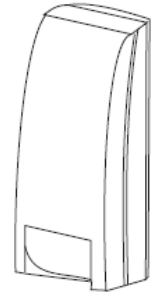

1. INTRODUCTION

NK PIR832 is a highly capable detector combined with newest and highest technology nowadays. It adopts predominant PIR device and CPU faint controlling technology which can recognize the entrance or exit direction, i.e.: when man is going outside or trigger the detector when moving in the house, detector will start its alarm-delay-timer for time calculation, if detector is triggered endlessly, timer will repeat time calculation and no alarm; but if there is no activation after delay time and there is intrusion signal from outside, such as climbing from window, entrance from door, it will trigger alarm

2. SPECIFICATIONS

- Power supply: 9-16VDC
- Current: 14mA
- Install high: 3.6m max
- Coverage: 6m*1.3m 12.5
- Alarm time: 3-5s
- Delay : optional
- Delay time: 40s/120s/240s optional
- Alarm direction: optional
- Microchip: 8 bit cmos
- Anti RFI/EMI: 0.1-500MHz/3V/m
- Anti-white light: >10000LUX
- Alarm output: 100mA/24V
- Tamper output: 100mA/24V
- Temperature: -10 / +55
- Humidity(RH): 95%
- Detect speed: 0.2m/s to 3.5m/s
- Dimensions(H*W*D): 70mm*28mm*25mm
- Color: white

3. INSTALLATION RECOMMEND

Installation Guidline

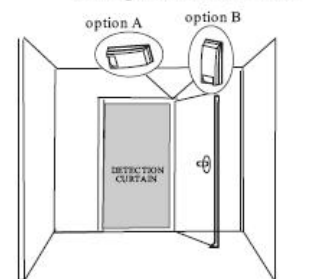
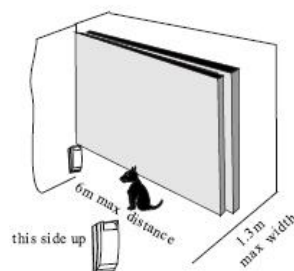
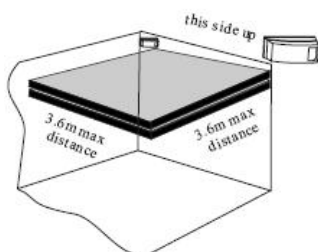
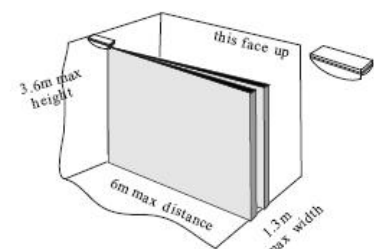
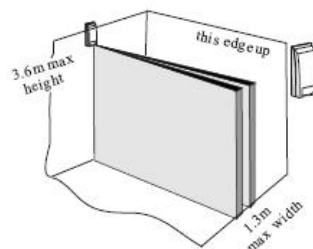
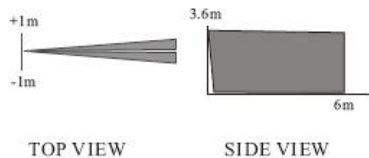

4. INSTALLATION GUIDE

Loose the screw with cross screw-driver to separate the front and back covers Move down the PCB, the back cover can be fasten to the content

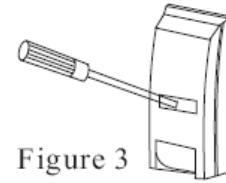

Figure 3

Fasten the back cover to installation position and combine the PCB to right position. Then close the front cover and fasten screw, then set correct the plastic board. One side be put to the flute and tightened, lean the other side to arch shape in order that it can be insert to the flute successfully.



Figure 4

5. SETTING

The Installation can be finished on different positions such as wall, ceiling and doorframe

Note: In order to avoid false alarm caused by external temperature change and air current, detector can not be installed on window frame on the external wall or inner part of the window frame. On the other side, the remaining space of connection part should be filled by mixture as RTV material to avoid entrance of insects or air current.

- A. Select a proper installation position where the intrusion path can block the infrared beams.
- B. For ceiling installation, the maximum installation height is 3.6m; and maximum detection distance is 6m. On this condition, the curtain width is 1.3m.
- C. For the maximum prevention of false alarm, keep the detector away from facing heat source, light source or windows under direct sunshine. And cable connection should avoid high pressure cable.
- D. Select proper installation place and height according to coverage range, fasten the motherboard with PCB board through the 2 installation holes.
- E. Installation surface should be steady.

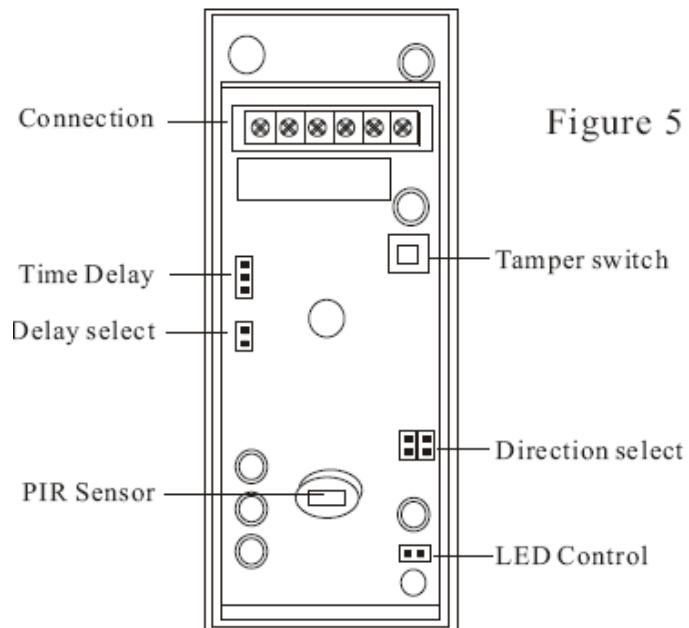

Figure 5

Connection

For cable connection, please use the connection slot on the left upside of detector.

- A. Connect the extremities 1 and 2 (N.C tamper extremities) to 24 hours N.C protection region on control board. When the front cover of detector is open, tamper switch is open.
- B. Connect the extremities 5 and 6 (N.C relay terminal) to N.C protection region on control board. When intrusion is detected or power is in trouble, alarm output loop is open.
- C. Connect extremities 3 (+) 4(-) to 9 -16V DC power (Care for polarity). Back up power should be equipped. Static current consumption on each unit is around 12.5mA.
- D. All hatches are suggested to be filled by rubber filler or glue after installation.

Figure 6

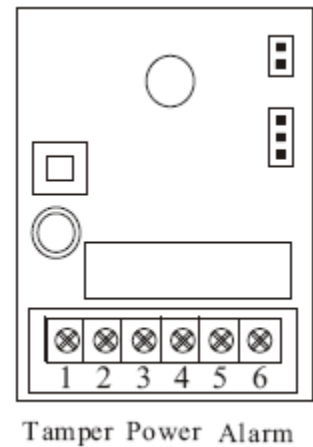

Walking test

Walking test: the system will need 1 minute for pre-heating after power connection, test can be operated after system is stable.

Cross the detection range in the effective area. Walking repeatedly can test out the alarm direction of the detector. If the alarm direction is on the contrary as installation requirement, please adjust "direction setting jumper" When delay function is needed, please refer to the usage direction on delay function .

Delay function introduction: detector can recognize the entrance/ exit direction, ie, when man is going outside or his indoor activity triggers the detector, detector will start delay time calculation (time is 40 seconds-4 minutes adjustable), if detector is triggered continuously, delay calculator will calculate the time repeatedly, detector will not send out alarm; but if continuous not-trigger status exceeds delay time, and detector receive external intrusion signal, for example, intruder climb in from the windows or through the door, it will trigger alarm immediately. (Red LED lights)

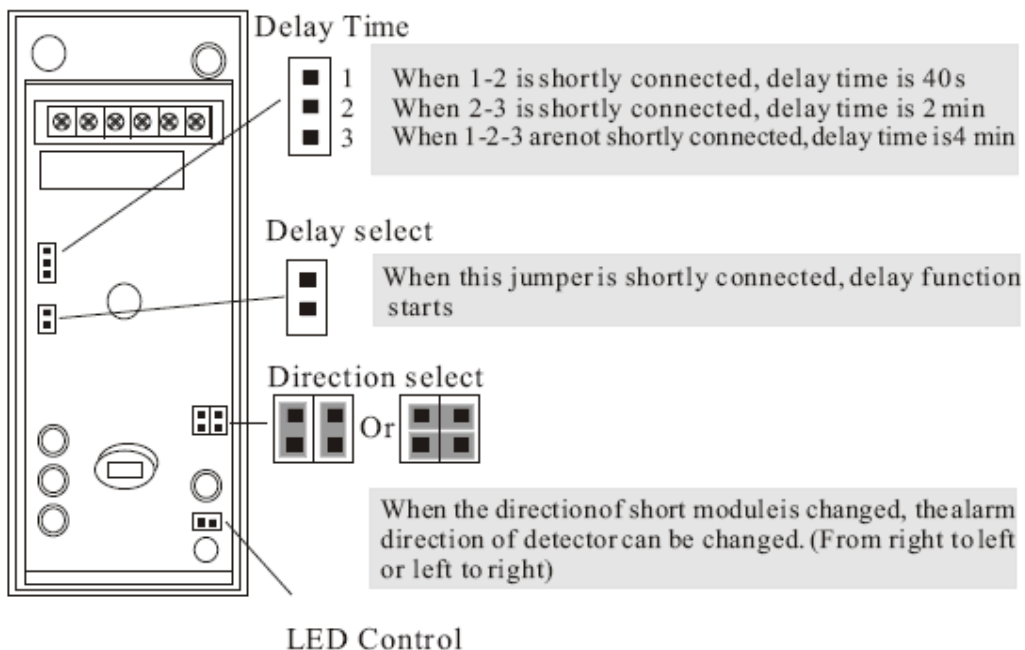

Figure 7

6. NOTES AND WARNINGS

Even the most sophisticated detectors can sometimes be defeated or may fail to warn due to :DC power failure/improper connection, malicious masking of the lens, tampering with the optical system, decreased sensitivity in ambient temperatures near that of the human body and unexpected failure of a component part. The above list includes the most common reasons for failure recommended that the detector and the entire alarm system be checked weekly, to ensure proper performance.

An alarm system should not be regarded as a substitute for insurance. Home & property owners or renters should be prudent enough to continue insuring their lives & property, even though they are protected by an alarm system.

This device has been tested and found to comply with the limits for a Class B digital device, pursuant harmful interference in residential installations .This equipment generates, uses and can radiate radio frequency energy and ,if not installed and used in accordance with the instructions ,may cause harmful interference to radio and television reception. However, there is no guarantee that interference will not occur in a particular installation .If this device does cause such interference, which can be verified by turning the device off and on ,the user is encouraged to eliminate the interference by one or more of the following measures:

- Increase the distance between the device and the receiver.
- Connect the device to an outlet on a circuit different from the one that supplies power to the receiver.
- Consult the dealer or an experienced radio/TV technician.

WARNING! Changes or modifications to this unit not expressly approved by the party responsible for compliance could void the user s authority to operate the equipment.